

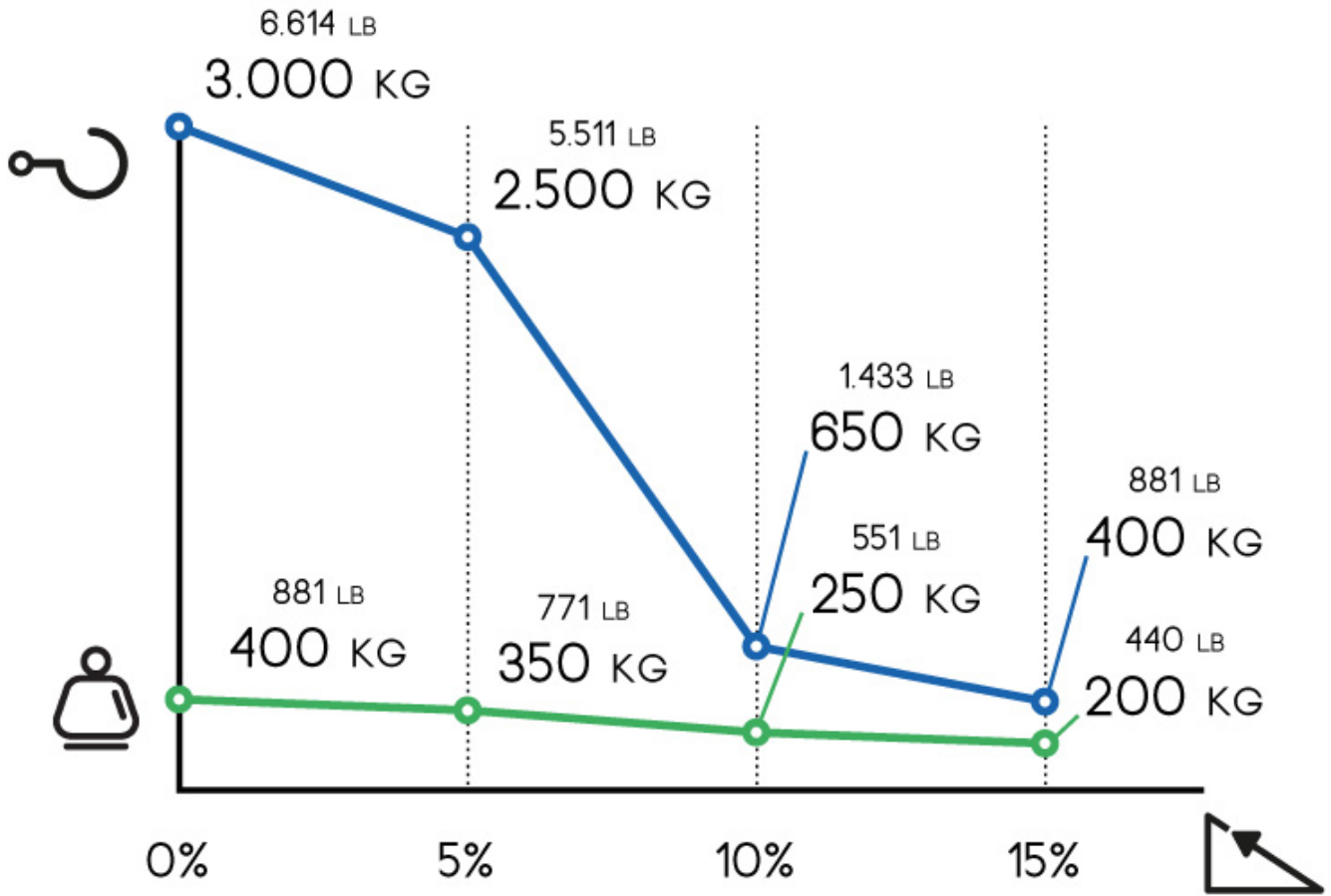

...the passion for moving

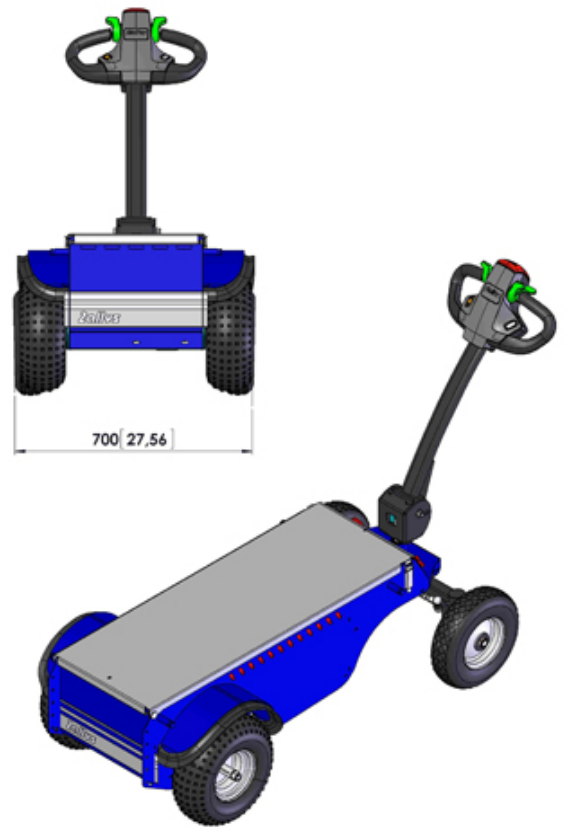

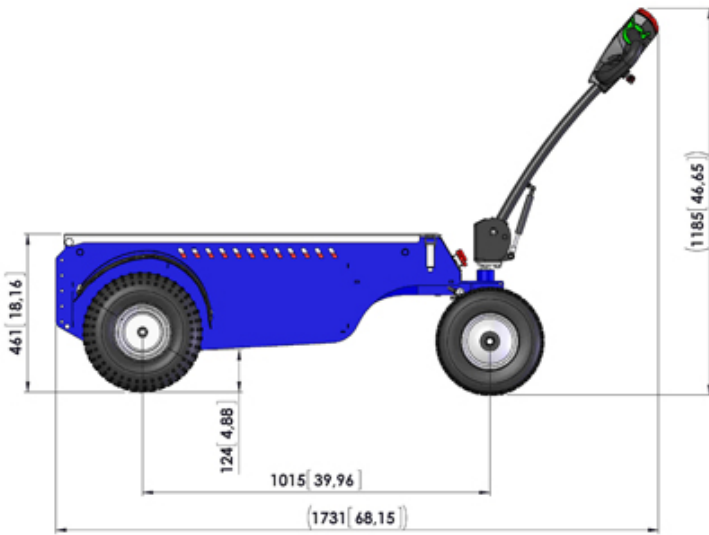

**Zallys**

TABLE:

**Z152.700**

**Range Max-T**

Unit: mm / [ inch ]

1:10

Characteristics		Tolerance	M.U.	.
1.01	Model number			Z152.720-1
1.02	Model name			RANGE MAX T
1.03	Manufacturer			ZALLY S
1.04	Operator			Pedestrian
1.05	Power unit			Electric
1.06	UL certification			
1.07	CE certification			

Frame characteristics		Tolerance	M.U.	.
1.80	Frame made of			Steel
1.82	Anti-Corrosion Treatment (on customer demand only)			Cataphoresis
1.83	Frame treatment			Polyester powder coating

Safety data		Tolerance	M.U.	.
2.01	Dead man safety system			Sensor on tiller head
2.02	Emergency reverse button			On tiller head
2.04	Creep speed device			Button on tillerhead
2.06	Power supply disconnection device / Emergency stop			Detachable power connector
2.10	Acoustic signaling			Electric horn
2.11	Drive controls			Maintained action switch

Performances		Tolerance	M.U.	.
3.01	Max. forward speed	± 5 %	km/h	4,5
3.02	Max. backward speed	± 5 %	km/h	4,5
3.06	Max.load capacity on flat ground		kg	400
3.11	Max.towing capacity on flat ground (max 3 min) **		kg	3000
3.15	Max.slope with load *		%	15
3.23	Max towing force at hook **		N	1600
3.38	* Load capacity is subject to kind of slope , kind of floor and operating time			
3.40	** While the force expressed in N at the hook remains unchanged, the following circumstances may affect the towing capacity expressed in KG : type of ground on which the towing is performed, the use (or not) of ballasts and type of wheels mounted on the vehicle and on the trailer			

Drive controls		Tolerance	M.U.	.
4.01	Type of control			Tillerhead
4.02	Type of start control			Butterfly lever

Standard batteries		Tolerance	M.U.	.
5.01	Batteries			2
5.02	Batteries type			Traction lead acid batteries
5.03	Battery voltage		V	12
5.04	Nominal Capacity 5 h		Ah	72
5.05	Nominal Capacity 20 h		Ah	96
5.06	Weight of each battery		kg	25

Optional battery specifications		Tolerance	M.U.	.
5.11	Batteries pcs			2
5.12	Batteries type			Traction AGM batteries
5.13	Battery voltage		V	12
5.14	Nominal Capacity k5		Ah	50
5.15	Nominal Capacity k20		Ah	70
5.16	Weight of each battery		kg	22

Optional battery specifications		Tolerance	M.U.	.
5.21	Batteries			2
5.22	Batteries type			Traction lead acid batteries
5.23	Battery voltage		V	12
5.24	Nominal Capacity k5		Ah	126
5.25	Nominal Capacity k20		Ah	167
5.26	Weight of each battery		kg	40

Available chargers		Tolerance	M.U.	.
6.40	Standard voltage		V	220/240
6.41	Multitension		V	110/240
6.42	Plug			In use in the country of destination

Technical data of standard charger		Tolerance	M.U.	.
6.01	Battery charger			External - high frequency
6.02	Input voltage		V	230
6.03	Input Frequency		Hz	50-60

Optional charger specifications		Tolerance	M.U.	.
6.14	Charger suitable for AGM batteries of		A	50/70
6.19	**for all other details please refer to standard charger specifications			

Drive motor		Tolerance	M.U.	.
7.03	Engine			Electric
7.04	Electricity			Direct current
7.05	Engine voltage		V	24

Technical data		Tolerance	M.U.	.
8.01	Transmission system			Mechanical
8.02	Transmission lubrication			In oil bath
8.06	Service brake			Electronic
8.08	Parking brake			Electro-Mechanical

Weight		Tolerance	M.U.	.
9.01	Weight without batteries		kg	93
9.08	Weight incl. 72/96A lead acid batteries		kg	143
9.09	Weight incl. 50/70A AGM batteries		kg	137

9.13	Weight incl. 126/167A lead acid batteries		kg	173
------	---	--	----	-----

Dimensions		Tolerance	M.U.	.
10.01	Length		mm	1731
10.02	Width		mm	700
10.03	Height of start control		mm	1185
10.08	Loading platform height		mm	461
10.14	Wheelbase		mm	1015
10.15	Turning circle		mm	4000
10.16	* with tiller in vertical position			
10.50	**For further details please click on technical draws			

Standard wheels		Tolerance	M.U.	.
11.01	Drive wheels			2
11.02	Steering wheels			2
11.05	Tyres			Pneumatic
11.06	Type of tyres			Turf tires
11.13	Drive tyres size			15-6.00-6"
11.14	Steering wheels size			4.10-3.50-6"
11.25	Inflation pressure		bar	2