

Please Note: These instructions pertain to the Motorized Hopper Cart and the 24V Motorized Transaxle Kit (part number MTK24) only.

BATTERY REPLACEMENT INSTRUCTIONS

Replacement Battery Specs: 12 volt, 12 amp/hour lead acid sealed, AGM type. MK Battery model number ES12-12 or equivalent. 2 batteries required.

- A. Turn unit upside down so that battery box is accessible.
- B. Remove the 4 M6 Screws that hold the lid on the battery box.
- C. Carefully remove the two batteries one at a time, and disconnect the spade terminals. Do not discard old batteries – please take them to a recycle center.
- D. Re-connect the battery and circuit breaker wires to the new batteries as shown. It is helpful to make the connections with the batteries outside the box first. The batteries are wired in SERIES, not parallel.

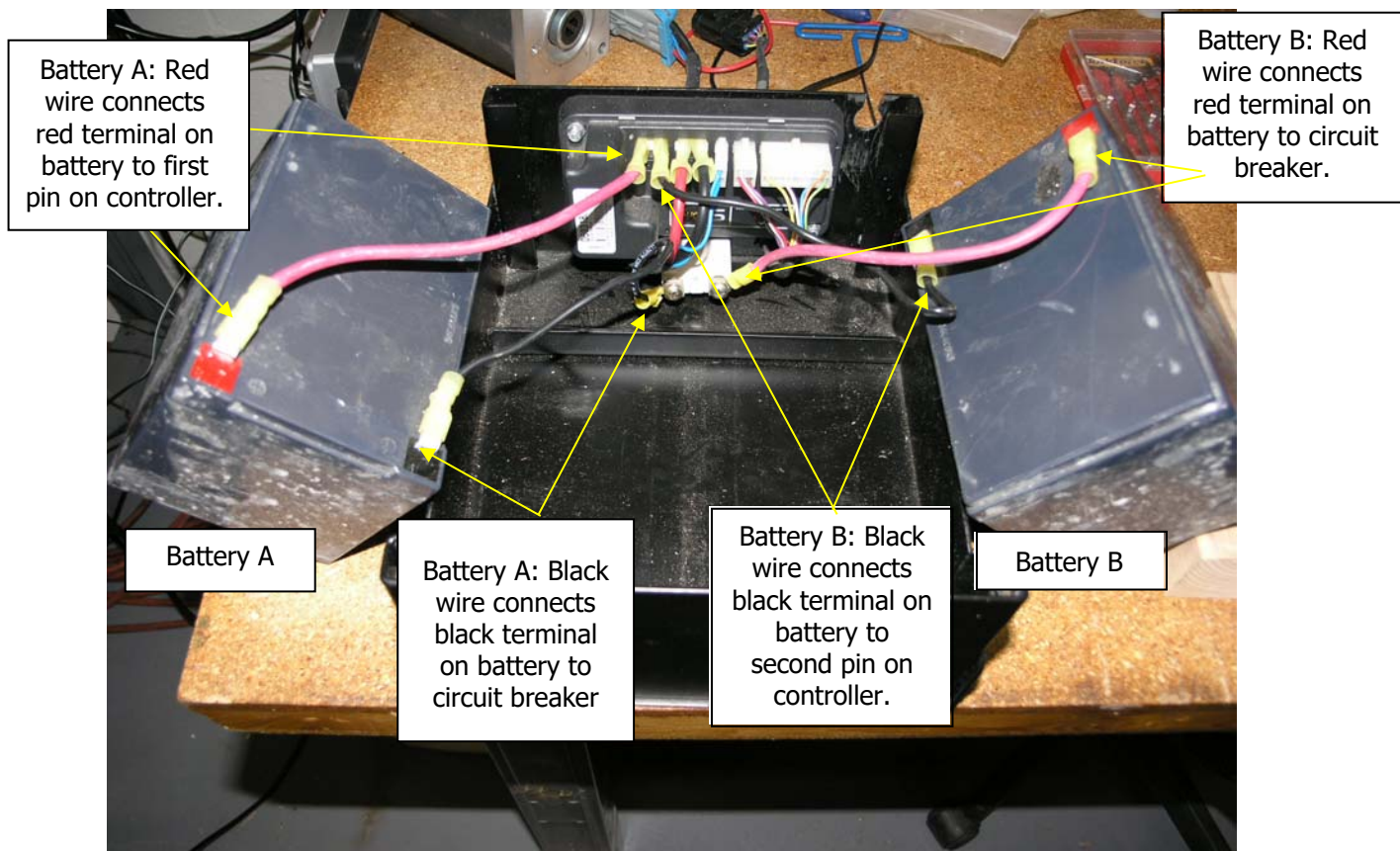

Make sure all terminals are tight. If they are loose, use a pair of pliers to carefully squeeze the spade connectors so they fit tightly onto the terminals

1. Place battery A into box first.



2. Place Battery B into the box making sure the wires are nested between the batteries and that no wires are detached. The fit is designed to be tight.



3. Replace battery box lid, and secure with 4 M6 screws.

DONE!

Wiring Diagram - 24V System

24V SYSTEM WIRING DIAGRAM

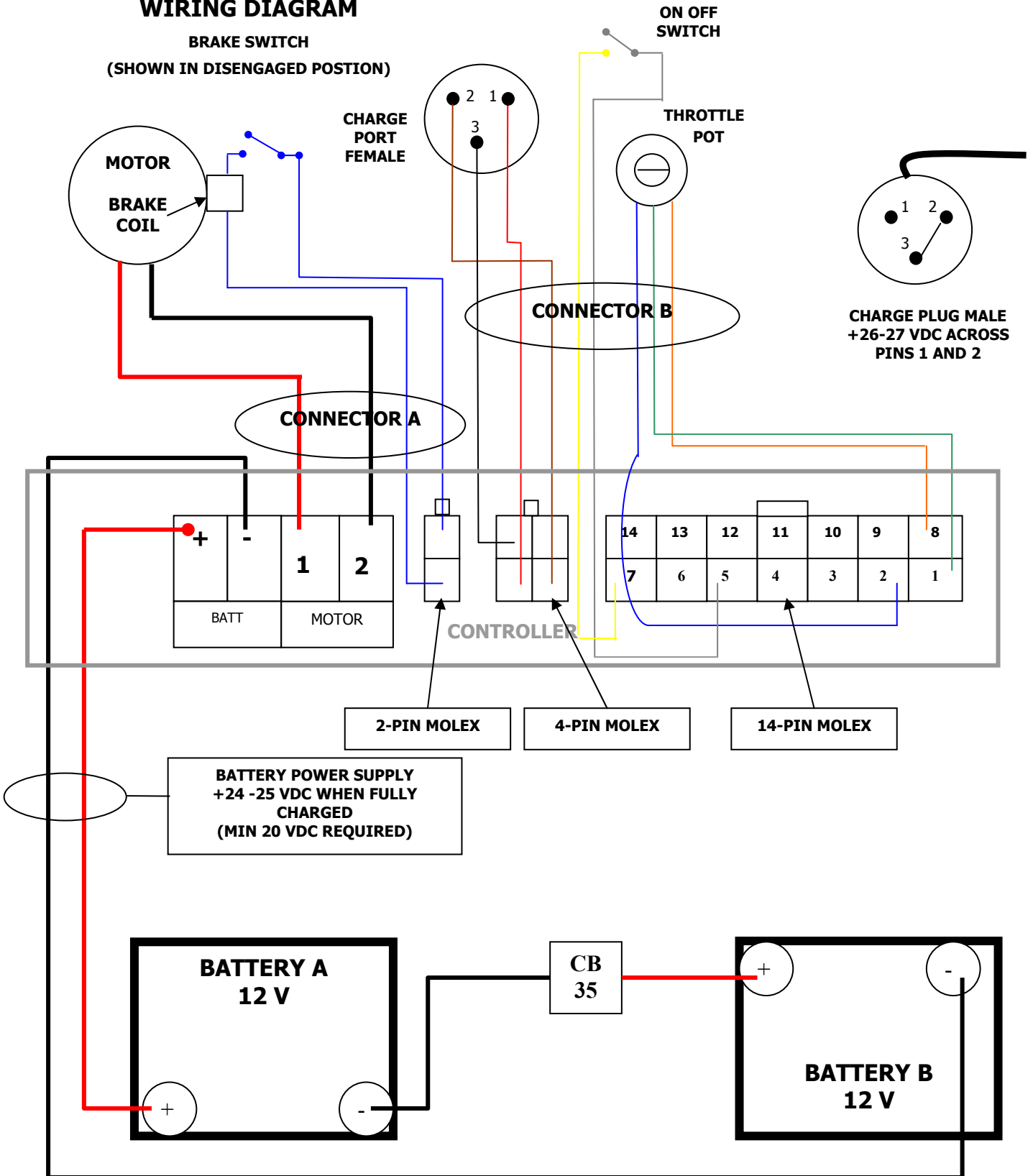

Troubleshooting

Problem	Possible Causes	Remedy
Motor does not run	Power switch in OFF position Controller in sleep mode Batteries are drained Motor brake lever released on drive system Electrical fault	Turn switch to ON position Cycle switch, OFF 2 sec, then ON Recharge batteries Re-engage motor brake on drive system Unplug, then plug in both motor and throttle connectors
Motor shuts off during use	Circuit breaker has tripped Controller trip due to thermal overload (weight and/or climb angle may exceed controller capacity)	Push circuit breaker to reset Release throttle, allow controller to cool down at least 30 seconds. Unload some weight, cycle power switch, operate machine again.
Insufficient range	Hilly or soft terrain Batteries not "broken in" Cold batteries Battery not fully charged Damaged, old batteries Low tire pressure	Push to assist drive system Charge and discharge 4-10 times before optimum range Keep batteries warm ALWAYS keep machine on charge when not in use Replace batteries Inflate tire(s) to recommended psi
Machine abruptly stops	Broken motor wire or connector	Check motor wires and brake wires to make sure none are broken, and also check connector to make sure wires are secure in connector
Machine slows down aggressively while in manual release mode	"Push too fast" safety feature	Do not push machine so fast while in manual release mode



MAGLINE® INC.

**1205 West Cedar Street
Standish, Michigan 48658
1-800-MAGLINE (624-5463)**

**Email: customerservice@magliner.com
www.magliner.com**