



Powered Lifting Hand Truck Owner's Manual

This manual applies to any Powered Lifting Hand Truck model beginning with "LTA" or "LTK."

Important Startup Instructions

1. Read the Owners Manual thoroughly before first use.
2. Charge the Powered Lifting Hand Truck for six hours before using it for the first time. If the Powered Lifting Hand Truck battery completely discharges, recharging will take 3 hours. See page 10 for battery and charging information.

Remove the rear cover of the Powered Lifting Hand Truck to find the serial number. The serial number is located in the lower right corner of the enclosure. See page 16 for instructions to remove the rear cover.

Serial #: _____

Date of Purchase: _____

Table of Contents

General Safety Instructions.....	3
Startup Instructions	4-7
Powered Lifting Hand Truck Unit.....	8
Powered Lifting Hand Truck Options and Accessories	9
Charging the Battery	10
Display Indicators.....	11
Using the Powered Lifting Hand Truck.....	12-13
Changing Lifting Noses	13
Moving with the Powered Lifting Hand Truck	14
Storing the Powered Lifting Hand Truck.....	14
Replacing the Fuse	15
Replacing the Battery.....	16
Maintenance.....	17
Troubleshooting Guide	18
Operating Labels.....	19
Replacement Parts.....	20-21
Regulations	21

Warranty

Magliner products have a one (1) year warranty unless otherwise specified from the date of purchase against defects in workmanship or material. Any part or component, except items covered by warranties of other manufacturers, returned to the factory or service center freight prepaid by the owner, found upon examination by Magline, Inc. to be defective or the result of improper workmanship by the factory will be repaired or replaced without charge and returned to the owner freight prepaid by Magline, Inc.

Alterations of Magliner products void any warranty or liability on the part of Magline, Inc.

Magline, Inc. does not guarantee product capacity if alterations are made.

Thank you for purchasing the Magliner Powered Lifting Hand Truck! If you have any questions regarding your new Magliner product please call our customer service department at 1-800-MAGLINE (624-5463) or (989) 512-1000. Please read this manual thoroughly to become familiar with the safe operation and maintenance of your new product.

General Safety Instructions

- Inspect before each use for damaged and loose fasteners/connections, particularly those found on the rails.
- Inspect the unit for cracks, wear or damage. Replace damaged components immediately.
- Keep hands and feet away from all moving parts.
- Never stand or sit on the lift attachment.
- Do not use this product to lift or to transport people.
- Never use as a step ladder.
- Never use on a moving vehicle.
- Never operate when any of the housing components have been removed.
- Keep all loose items away from the lift screw, as they may become entangled during use.
- Never use or store in wet environments or get any of the unit wet. The unit may be used indoors or outside, but always use caution to keep the unit from getting wet; dry as soon as possible.
- Never exceed the rated weight capacity of the lifting nose. Do not exceed the fixed nose carrying capacity of 500 lbs. Damage to the lift and personal injury could result.
- Use extreme care when raising or lowering in close proximity to other objects. Hands and other items may get pinched or injured as the moving attachment passes non-moving objects.
- Never place a load's center of gravity over the front edge of the lifting nose; always keep the load center of gravity centered on the lifting nose.
- Never tilt the unit back with a raised load, unless it is done slowly to balance the load over the wheels when pushing the hand truck. If there is no load on the fixed nose, do not raise the load higher than the halfway point of the frame.
- Never go over a curb or any other multi-level transition with a raised load.
- Do not operate when the battery charger is plugged in.
- Never attempt to open the battery. If the battery is cracked or leaking, do not recharge it - it must be replaced.
- Always use a Magliner battery charger to charge your battery (part number 63081).

Startup Instructions

Before beginning the startup process, inspect the conditioning of packaging for damage to the Powered Lifting Hand Truck. If damage is found, contact Magline Technical Assistance.

You should have received the following items with your order:

- Lifting column assembly
- Lifting nose
- Fixed nose plate
- Handle
- Hardware
- Accessories
- 3/16" Allen wrench

If you are missing any of these items, please contact your authorized Magliner dealer, or Magline Customer Service at (800) 624-5463.

Product Assembly

Charge the battery for three hours before using it the first time. For more information on charging, please refer to page 10.

Description	Qty.	Part No.
Fixed nose plate	1	521182
Flat head screw - 5/16"-18 x 1-1/4" long	4	802030
Flat head screw - 5/16"-18 x 1-3/4" long	2	802036
Hex lock nut - 5/16"-18	2	80676

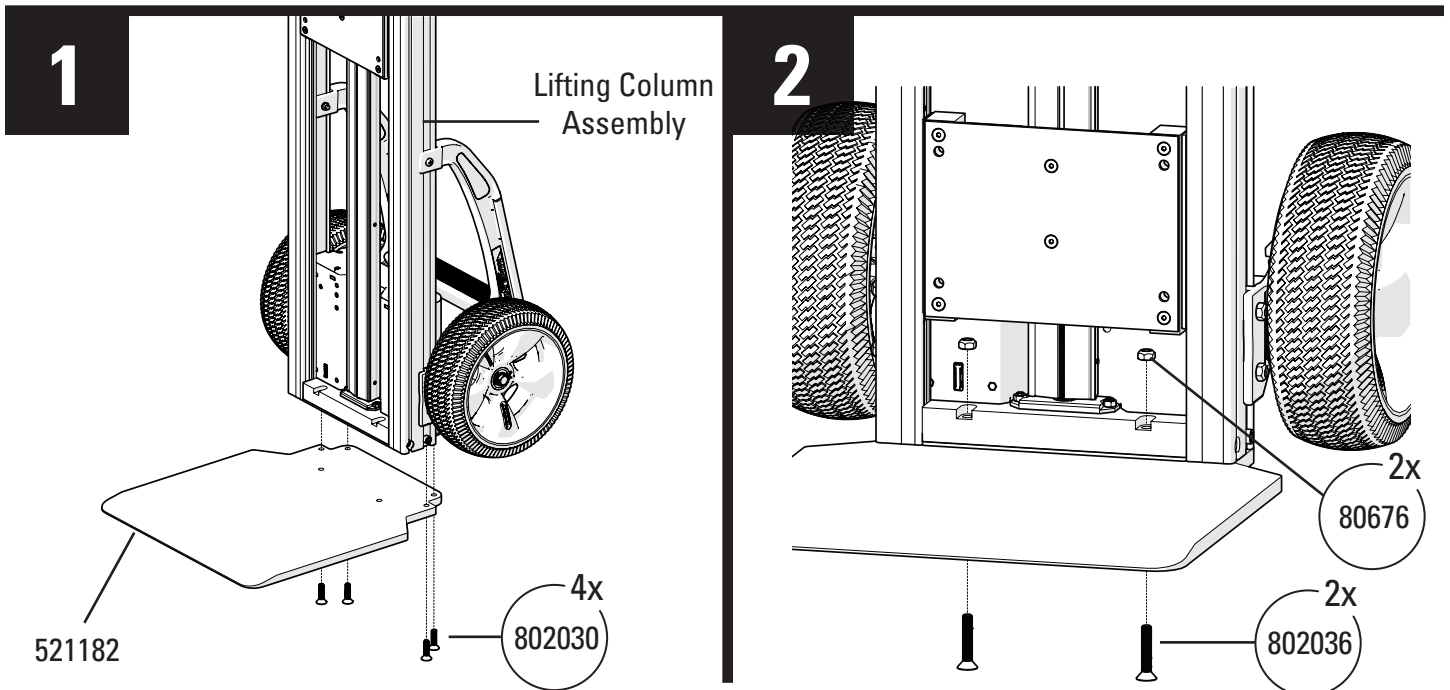
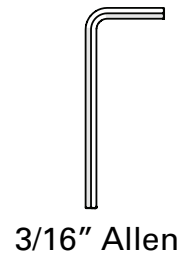

Description	Qty.	Part No.
Handle	1	Varies
Pan head machine screw - 1/4"-20 x 1-1/2" long	4	80105
Hex lock nut - 1/4"-20	4	80675



No. 3

7/16"

3

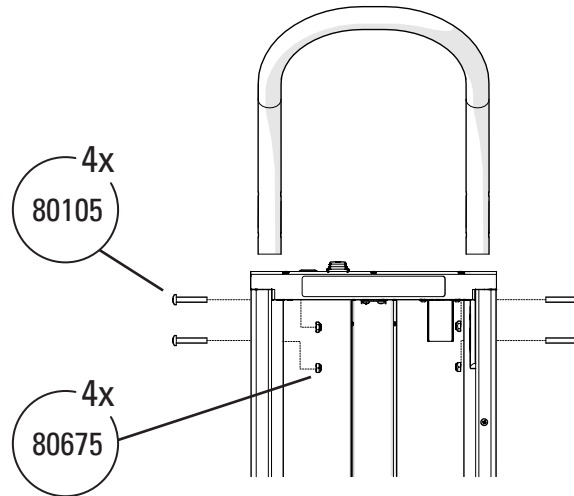

Before assembling the lifting nose to the lifting column assembly, it is important to perform a test of the lift system.

4

Unloaded Lift System Test

NOTE: It is good practice to periodically perform lift system tests, especially if the Powered Lifting Hand Truck has not been used for a long period of time, or used by another operator.

Check these things WITHOUT A LOAD:

Check Power Control

- ON - Press and release the ON/OFF button. The battery charge indicator will light on the display.
- OFF - Press and hold the ON/OFF button until the display shows POWER OFF (about 4 seconds). Release the button and the display will go blank.

Check Speed Function

- Locate the UP/DOWN switch with the carriage at lowest location.
- Press the switch in the UP direction and observe carriage lifting. Observe the speed change after holding the button for 4 seconds. Then release the button to stop.
- Pressing UP again will restart the speed at the low speed setting. **DO NOT CONTINUE UP UNTIL LIMIT SWITCH CHECK (NEXT STEP).**

Up/Down Operation Check**Up Operation**

- Locate the upper switch below the top plate.
- Locate the lever (silver strip) and press lightly; you should hear a click.
- Locate the UP/DOWN switch and press and release in the up UP direction and observe the carriage lifting up.
- With the lift carriage sufficiently away from the upper switch (example: about the center of the machine). Press and hold the switch in the UP direction and depress the upper limit switch to stop movement. The display should show "LIM" when the limit switch is activated. **(If pressing the upper limit switch does not stop upward movement, call Magline.)**
- Remove your hand from the limit switch and run the carriage up until it contacts the limit switch and stops.

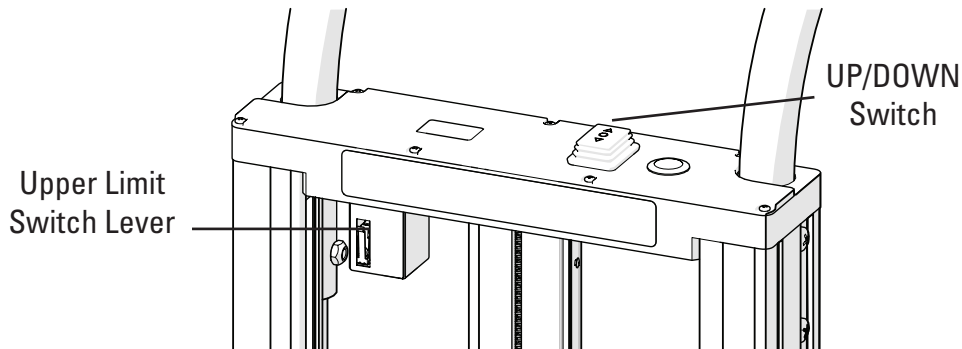
**Down Operation**

- Locate the lower limit switch at the lower left corner of the fixed nose plate (when viewing the machine from the front).
- Locate the lever (silver strip) and press lightly; you should hear a click.
- Locate the UP/DOWN switch and press and release in the DOWN direction and observe the carriage lowering.
- With the lift carriage sufficiently away from the lower switch (example: about the center of the machine), press and hold the switch in the down direction and depress the lower limit switch to make the movement stop. The display should show "LIM" when the limit switch is activated. **(If pressing the lower limit switch does not stop downward movement, call Magline.)**
- Remove your hand from the limit switch, and run the lift carriage down until it contacts the limit switch and stops.

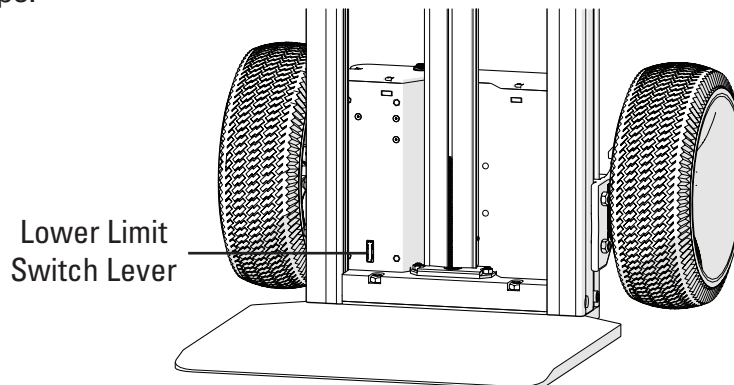

4 *...continued from previous page*

Cycle Test

Cycle the lift carriage up and down to the limit switches to check performance and to become familiar with the speed change. Be sure to keep fingers away from the front of lift carriage while it is in motion.

5

Description	Qty.	Part No.
Lifting Nose Options	-	Varies
Truss head screw - 5/16"-18 x 1" long	4	802040
Bronze bearing - 5/16" ID x 3/8" OD x 1/2" long	4	18085



No. 3

Fasten the 802040 bolts into the lifting carriage, leaving a small gap between the bolt head and the lifting carriage.

Carefully slide the larger portion of slots on the lifting nose over the hardware and slide straight down so that the smaller portion of slots are snug around the bolts, and is trapped between the bolt heads and the lifting carriage. You may need to slightly loosen the bolts if the initial tightening did not allow enough space for the lift nose.

Make sure the lifting nose sits evenly on all four bolts and that the lifting nose surface is level. Then securely tighten the bolts to secure the lifting nose to the lifting carriage.

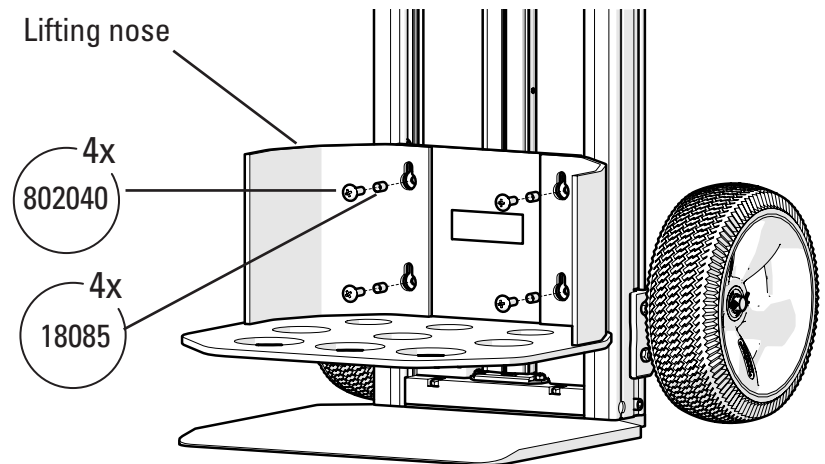

6

Repeat Cycle Test with a Load

NOTE: It is good practice to periodically perform lift system tests, especially if the Powered Lifting Hand Truck has not been used for a long period of time, or used by another operator.

The load should stop in the same spot. Place a load on the lifting nose and run the nose UP and DOWN to the limit switches, first contacting the limit switches in the low speed and then the high speed to become familiar with the operation.

Powered Lifting Hand Truck Unit

Model No.	Weight (lbs.)	Dimensions (in.)
LTA1281E-5	70	20-1/2" w x 48" h x 27" d

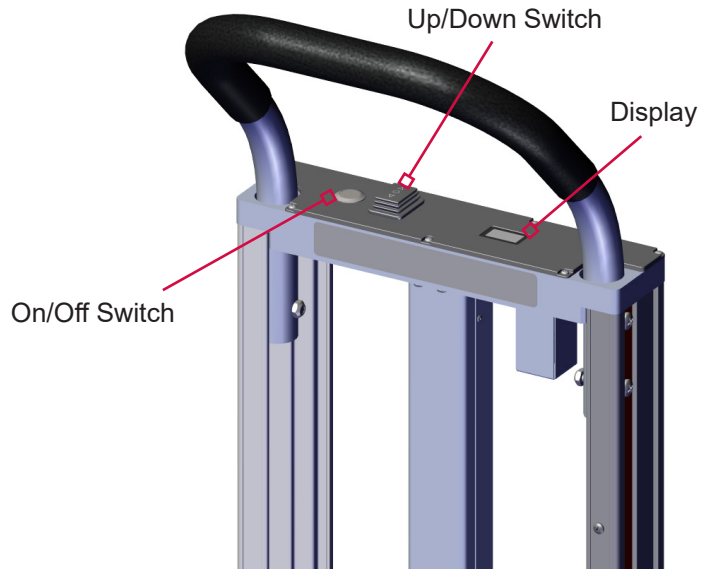
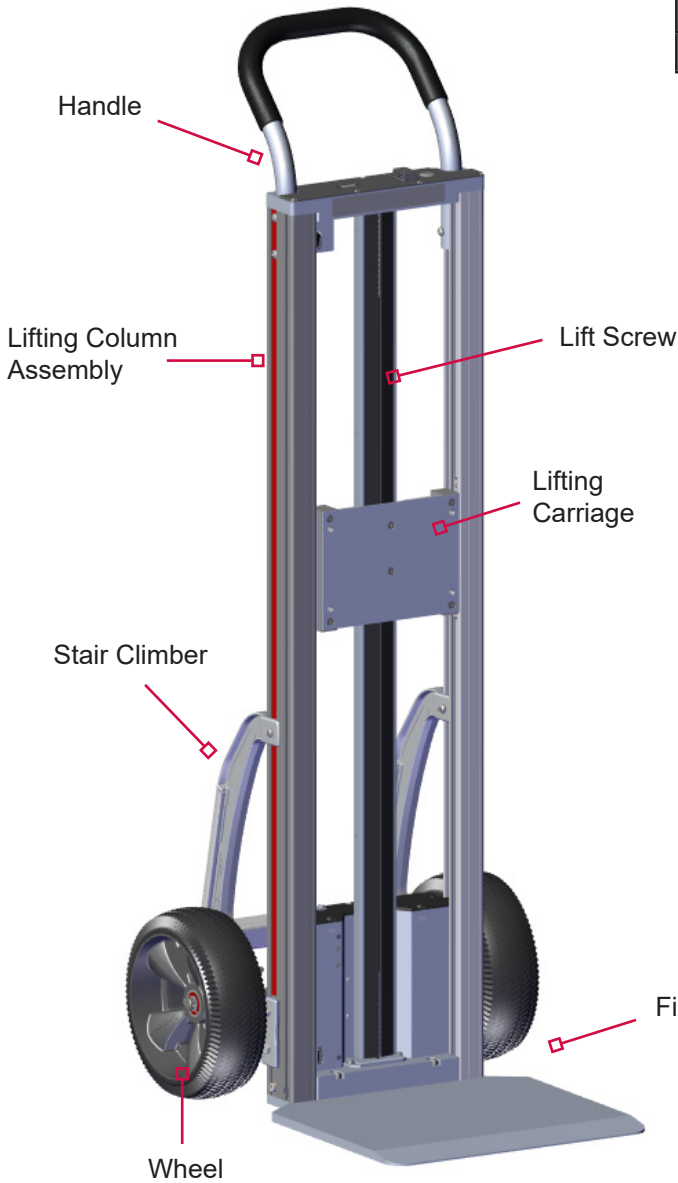

Fixed Nose

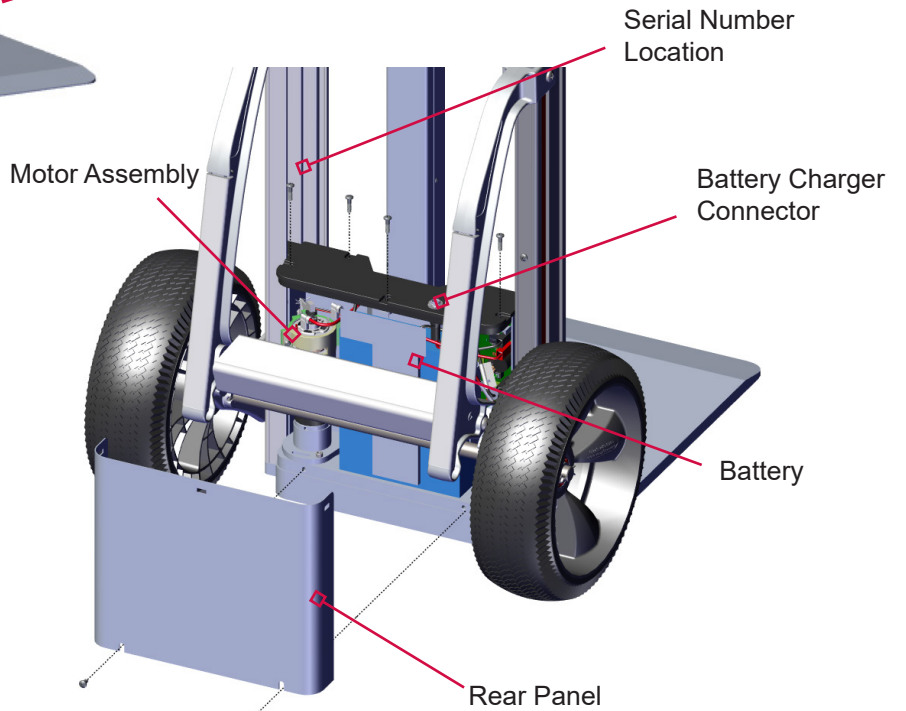

Battery Charger



Powered Lifting Hand Truck Options/Accessories

Handle Options



No. 11 -
301000



No. 19 -
301008



No. 18 -
301005



No. 24 -
301001



No. 28 -
301188



No. 17 -
301004



No. 30 -
301137

Lifting Nose Options

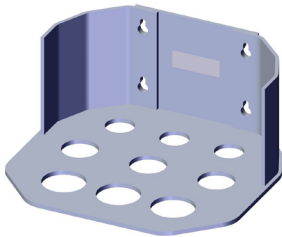

Lifting Nose - 521725
200 lbs. capacity

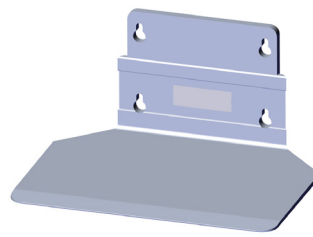

Lifting Nose - 521730
125 lbs. capacity

Wheel Options



10" x 3.5"
4-ply Pneumatic -
121060



10" x 3.5"
Microcellular Foam -
131010



10" x 3.5"
Interlocking
Microcellular Foam -
111080



10" x 2"
Interlocking
Microcellular Foam -
111070



10" x 2.75"
Interlocking
Microcellular Foam -
111075

Accessories

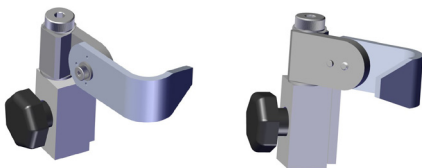

Keg Stabilizers - 521910

Battery

The Powered Lifting Hand Truck must be charged for three hours before using it the first time. If the Powered Lifting Hand Truck battery completely discharges, recharging will take three hours. Check the display on the Powered Lifting Hand Truck for state of charge. Always check the charger function before use (a green charging light will illuminate when in use). If the charger is not functioning properly, replace the charger before attempting to charge the battery.

General Battery Warnings

- Do not connect accessories to the battery; this will cause premature battery failure.
- Unauthorized modification could create a hazardous condition and result in serious injury.
- To prevent electrical shock, do not touch non-insulated parts of the charger output connectors, battery connectors or battery terminals. Do not use connectors that are cracked, corroded, or do not make adequate electrical contact. Use of damaged or defective connectors could result in fire or electrical shock.
- Keep sparks, flame and smoking materials away from batteries.
- Batteries can supply a large amount of current. Do not wear jewelry or watches when working on the batteries as an accidental shorting could occur and cause severe burning.

Battery Life

The Powered Lifting Hand Truck is powered by one 19.2V 5Ah lithium battery (LiFePO₄).* The lift motor draws current from the battery based on the amount of effort required to lift the load. A fully-charged battery will power 90+ lift cycles with a 160 lbs. load; however, extreme temperature ranges and extreme loads can have an effect on the amount of power available during one charging cycle.

General Charging Warnings

- Use only the Magliner-approved 19.2V charger designated for use with Powered Lifting Hand Truck (part number 63081). Charge using a grounded 120V electrical outlet.
- Do not operate the unit when the battery charger is plugged in.
- Do not expose charger to rain or snow.
- To prevent risk of fire, use the charger only in a dry, well ventilated room without flammable fluids or explosive gases.
- Make sure the cord is located such that it will not be a trip hazard or otherwise subject to damage or stress.
- Do not operate a charger with a damaged cord or plug – replace immediately.
- To reduce risk of electrical shock, unplug the charging unit from the AC power supply source before attempting any maintenance or cleaning.
- Always use battery chargers supplied by Magline, Inc. Other battery charging units could cause damage to your batteries or personal injury.
- To avoid damage to battery charger connectors and cords, disconnect by grasping the plug body and pulling it straight out of the outlet or receptacle. DO NOT pull on the cord. DO NOT twist, rock, or pull the connector sideways.
- The metal tip on the end of the plug may be hot when it is first unplugged.

*Battery has a warranty of six (6) months

Display Indicators

Startup Sequence

Within 1 second of pressing the Power button to turn ON, code revision data and the serial number flashes on the display. Then the battery gauge indicator increases until it reaches current state of charge.

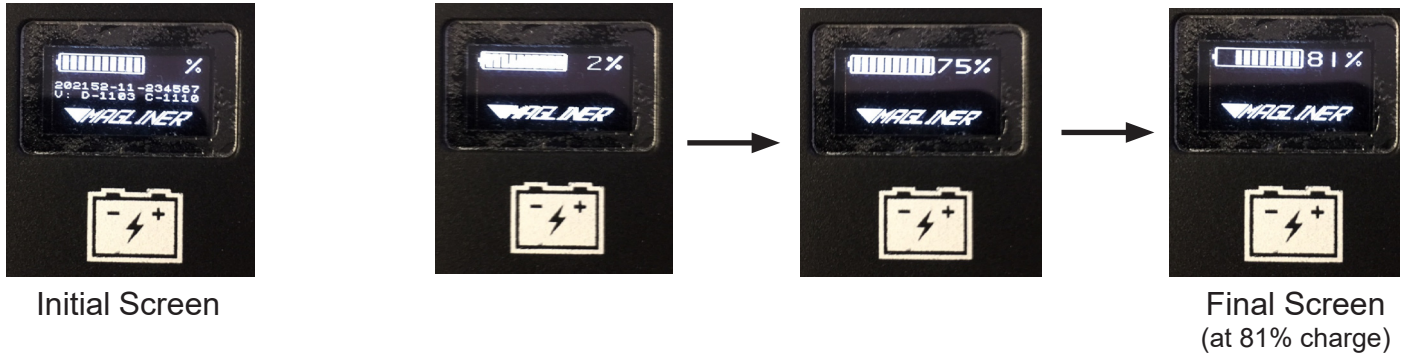

Normal Operations:

With the Powered Lifting Hand Truck turned On and operating normally, the gauge will indicate the calculated battery status via the 10-segment bar graph. Ten segments indicate that the batteries are fully charged, and as battery charge is depleted, the segments will disappear.

Charging Operations:

Once the Powered Lifting Hand Truck is placed on charge, the gauge will indicate the status of the charge. When all 10 segments of the bar graph are visible, the batteries are completely charged.

Limit Switch:

When a limit switch is activated, "LIM" will appear on the display.

Power Off:

Press and hold the power button until "POWER OFF" is displayed. The Powered Lifting Hand Truck is now turned Off.

Other Codes:

- "Link" - internal fault; contact Magline for more information
- "LOBAT" - low battery
- "CURR" - over current fault; contact Magline for more information



Using the Powered Lifting Hand Truck

ON/OFF Operation

1. To turn the unit ON, press and release the ON/OFF button. The battery charge indicator will light on the display.
2. To turn the unit OFF, press and hold the ON/OFF button until the display shows POWER OFF (about 4 seconds).
3. The Powered Lifting Hand Truck does not “sleep” when left on, but not being used. Please be sure to turn the unit OFF when not in use.

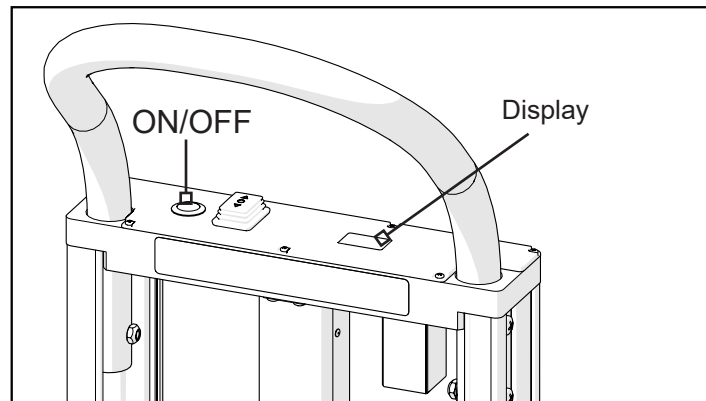

Lift/Lower Operation

1. Practice operating the hand truck without a payload before you use it to lift or move anything.
2. Press and release the ON/OFF button. The battery charge indicator will light on the display.
3. Locate the UP/DOWN switch and press in the up UP direction. The lift carriage and lifting nose will move upward in slowest speed to start; after holding the switch for more than 4 seconds, the speed will increase. Release the directional switch to stop.
4. When the directional switch is pressed again, lifting will begin in slow speed.
5. To lower the load, press the UP/DOWN switch in the DOWN direction. The lift carriage and lifting nose will move downward in the slowest speed to start; after holding the switch for more than 4 seconds, the speed will increase. Release the directional switch to stop.
6. When the directional switch is pressed again, lifting will begin in slow speed.

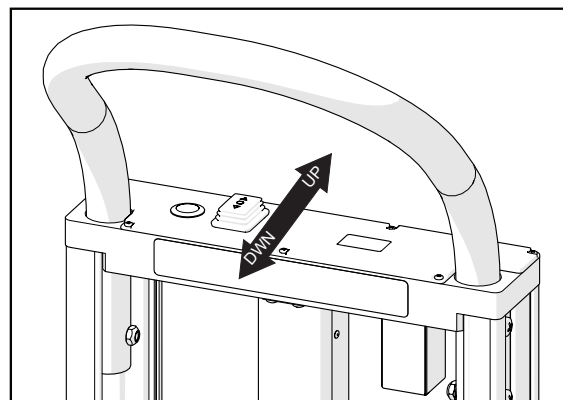

Loading the Powered Lifting Hand Truck

1. Do not exceed the load capacity of the lifting nose.
2. Place the hand truck on a flat, level surface before loading.
3. Be sure the load's center of gravity is located as close as possible to the center or rear of the lifting nose. When loading the hand truck, a balanced, stable load is best.
4. For added load stability, keg stabilizers or tie-down straps may be used. Ensure the load is fully secured using a tie-down strap before lifting or moving. Do not allow strap(s) to hang down below the bottom of the lifting nose. Do not attach strap to the frame; attach strap to the lifting nose to allow for movement up and down the frame.
5. It is beneficial to practice lifting and lowering a new type of load until you are able to lift and lower the load with maximum stability.

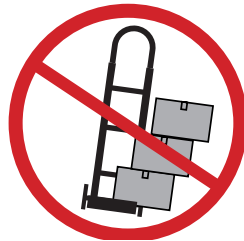

Changing the Lifting Nose

1. Lift or lower the lifting carriage to comfortable height.
2. To remove the lifting nose, loosen (but not fully remove) the 4 lifting nose mounting bolts.
3. Slide the lifting nose straight up so that the larger portion of slots on the lifting nose surround the bolts. Carefully pull the lifting nose away from the lift carriage to remove from the Powered Lifting Hand Truck.
4. Carefully slide the larger portion of slots on the different lifting nose over the hardware and slide straight down so that the smaller portion of slots are snug around the bolts, and is trapped between the bolt heads and the lifting carriage.
5. Make sure the lifting nose sits evenly on all four bolts and that the lifting nose surface is level. Then securely tighten the bolts to secure the lifting nose to the lifting carriage.
6. There should be a small gap between the lifting nose mounting bolt heads and the lifting carriage.

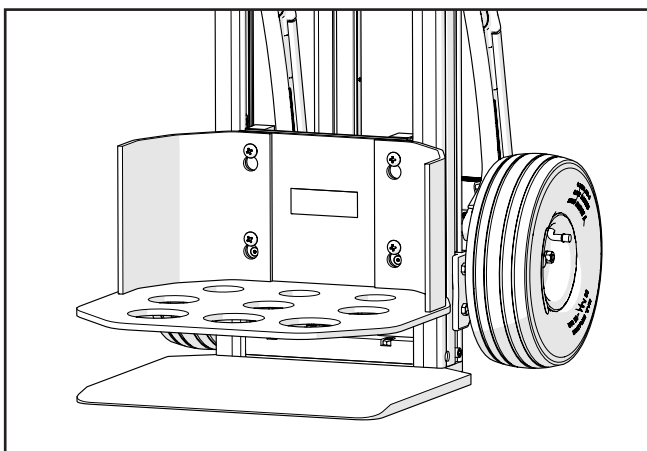

Lifting Nose for Cylindrical Loads

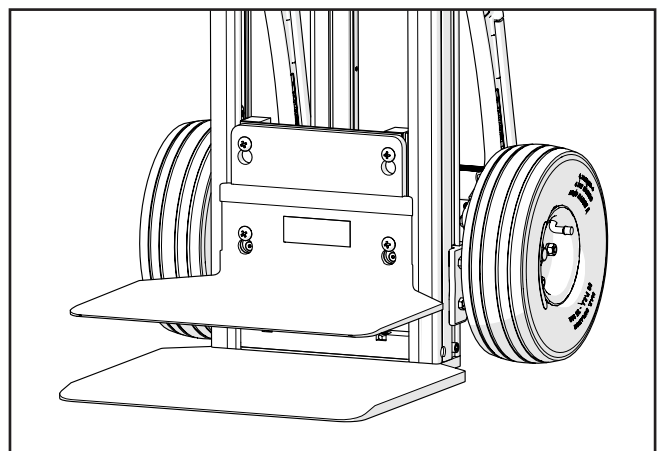

Lifting Nose for Flat Loads

Moving with the Powered Lifting Hand Truck

1. Always stay behind the unit when moving it. Operator should be positioned uphill from the Powered Lifting Hand Truck when descending on natural grades, sloping or uneven surfaces.
2. Never turn the unit quickly - this can cause the load to slide off the lifting nose.
3. Avoid making significant level changes in the lifting nose when the hand truck is broken back or is moving. It is acceptable to make small adjustments in height. Tip: It may be easier to balance the load when the lifting nose is approximately 6" from the ground, or by centering the load mass over the wheels when in the broken-back position. Never tilt the unit back with a raised load, unless it is done slowly to balance the load over the wheels when pushing the hand truck. If there is no load on the fixed nose, do not raise the load higher than the halfway point of the frame.

Storing the Powered Lifting Hand Truck

1. Never leave the Powered Lifting Hand Truck unattended in an aisle.
2. The Powered Lifting Hand Truck may be stored upright in a vehicle while strapped in place to prevent falling, or it can be stored lying on its side. In either position, take care to protect the following areas of the Powered Lifting Hand Truck from damage from falling objects or other loose objects in the vehicle:
 - Upper and lower limit switches
 - Lead screw
 - Dashboard and controls
 - Lower battery/electrical panel

Changing the Fuse

1. Make sure the charger is disconnected from the unit.
2. Turn the power switch to "Off."
3. Using a Phillips screwdriver, remove the five screws securing the rear cover to the enclosure. Remove the rear cover.
4. Inspect the fuses to determine which one is broken. It may be helpful to disconnect the red and black battery connectors from the circuit board terminals (see steps next page)
5. Carefully remove the broken fuse, taking care to keep the fuse fully intact.
6. Insert the new fuse, taking care to insert a fuse of correct amperage. Reconnect red and black batter connectors from the circuit board terminals, if disconnected (see steps next page).
7. Reinstall the rear cover and screws.

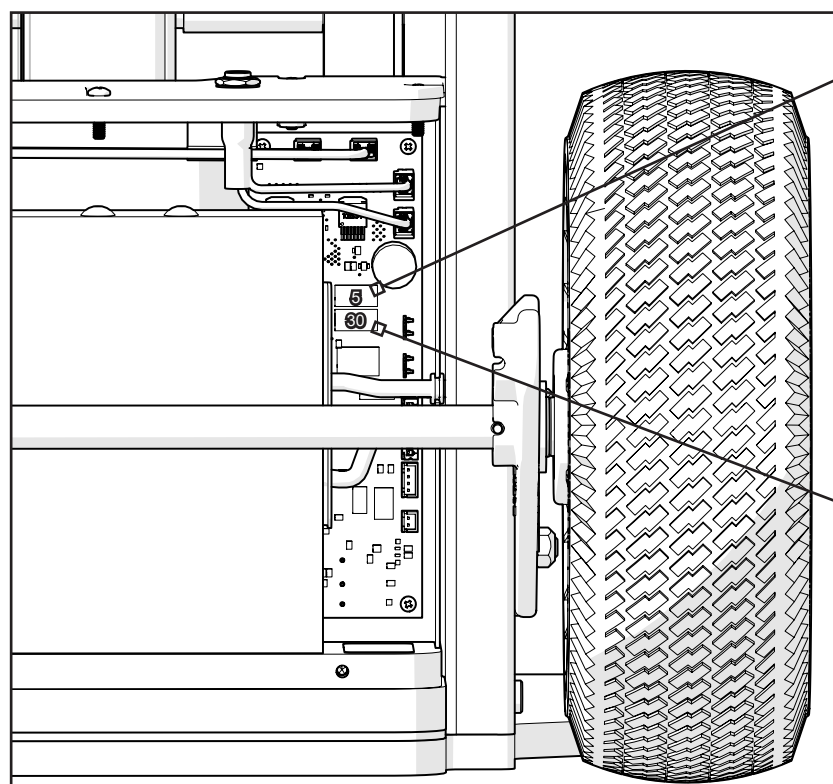
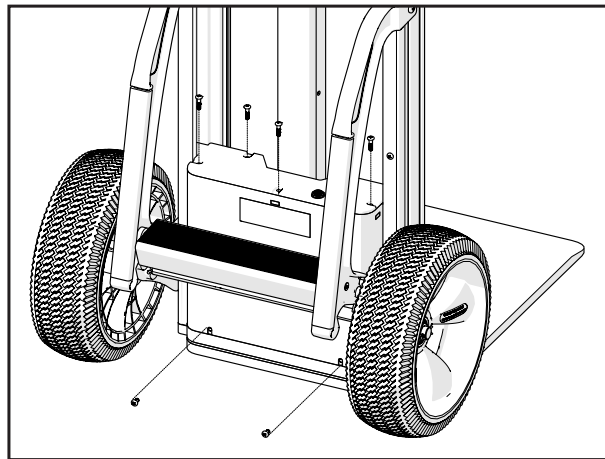

Top: 5 Amp
charge fuse

Bottom: 30 Amp
controller fuse

*Stair climber and kick bar
removed from image for clarity.*

Replacing the Battery

If the unit appears sluggish even after charging or if the battery does not hold its charge for very long, the battery may need to be replaced. Use only Magliner replacement parts. The battery has a warranty of six (6) months.

Caution: Never attempt to open the battery. If the battery is cracked or leaking, do not recharge it; the battery must be replaced.

1. Make sure the charger is disconnected from the unit.
2. Turn the power switch to "Off."
3. Using a Phillips screwdriver, remove the five screws securing the rear cover to the enclosure. Remove the rear cover.
4. Squeeze and pull the red and black connectors to remove them from the circuit board terminals (see Figure 2a).
5. Carefully slide the connectors off of the red and black terminals.
6. Inspect the battery for cracks, leakage, or corrosion. If you find cracks, leakage or corrosion on the battery:
 - a. Contact Customer Service toll free at (800) 624-5463. Do not operate the unit until repairs are made.
 - b. Do not let the leakage get onto your skin. Wear acid-resistant gloves and chemical goggles.
 - c. If leakage gets onto the skin, flush immediately with water and mild soap. If irritation develops, seek medical attention. If the leakage gets into the eyes, flush with clean water for 15 minutes and seek immediate medical attention.
8. Remove the battery.
9. Clean any dirt or debris from the battery compartment.
10. Place the replacement battery into the battery compartment.
11. Slide the red and black wire connectors onto the matching battery terminals - connectors should "click" into place. If the connectors do not fit securely on the battery terminals, contact Customer Service toll free at (800) 624-5463.
12. Reinstall the rear cover and screws.

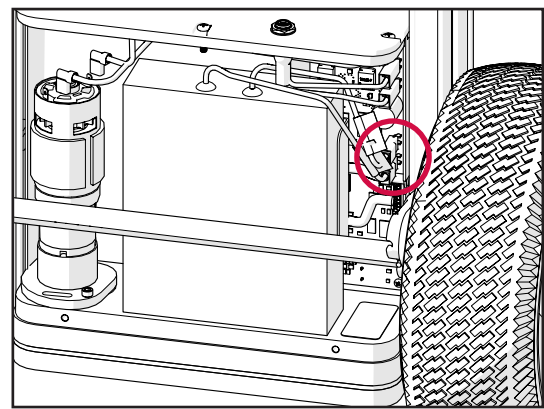
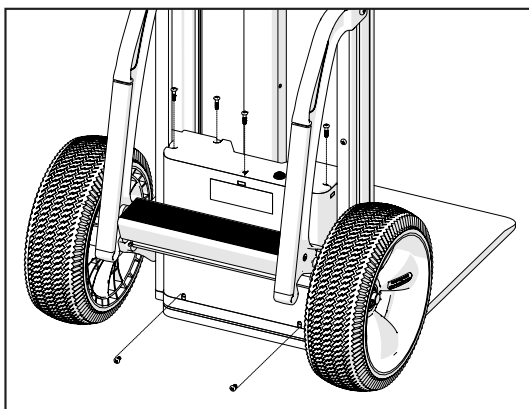

Stair climber and kick bar removed from image for clarity.

Maintenance

Area	Inspection Frequency	Procedure/Normal Condition
Outside Surfaces	Daily	Keep clean and dry. Replace any cracked or missing covers.
Fasteners	Daily	Tighten any loose hardware.
Battery Charging	Daily	Green charging light should turn red when charging.
Wheels	Daily	Inspect wheels and tires for wear and cracks.
Rolling Function	Daily	Unit should roll easily
Lift Carriage	Daily	Inspect for wear or damage. Lift carriage should move up and down smoothly.
Lift Screw	Daily	Inspect before each use; keep free of dirt and debris. Lifting and lowering motions should be smooth.
Lifting Nose/ Accessories	Daily	Inspect for wear and damage; replace as needed.

Troubleshooting Guide

Problem	Solution(s)
The lift does not respond, and does not make any noise when the lift switch is activated.	<ol style="list-style-type: none">1. Is the power switch turned on?2. Check the battery connections.3. Recharge the battery.4. Replace the battery.5. Check the fuse.
The lift struggles to raise objects and works very slowly.	<ol style="list-style-type: none">1. Check for dirt or other obstruction around the lift screw.2. Recharge the battery.3. Replace the battery.
The lift will not raise, but will lower.	<ol style="list-style-type: none">1. Check the display for a LOBAT warning and check the battery level.
The unit will not charge.	<ol style="list-style-type: none">1. Check to make sure the charger is fully plugged into the outlet and the charging port of the unit.2. Check that the charger LED is green then changes to red when plugged into the unit (with a battery).3. Check that the battery is connected.

Powered Lifting Hand Truck Label Placement

<p>MAGLINER® No. PLHT123456</p>	<p>Model: LTXXXXXXX Magliner®, Inc. 1205 W Cedar St. Standish, MI 48658 USA 800-624-5463 www.magliner.com/regulations</p>	<p>FC This device complies with part 15 of the FCC Rules. Operation is subject to the following two conditions: (1) This device may not cause harmful interference, and (2) this device must accept any interference received, including interference that may cause undesired operation. CAN ICES-003(A) / NMB-003(A)</p>
---	---	---

Part Number: 98344

WARNING

Read the Operator's Manual and all labels before use.
Do not exceed rated lifting capacity:
Standard lifting nose: 125 lbs.
Keg lifting nose: 200 lbs.

Part Number: 98340

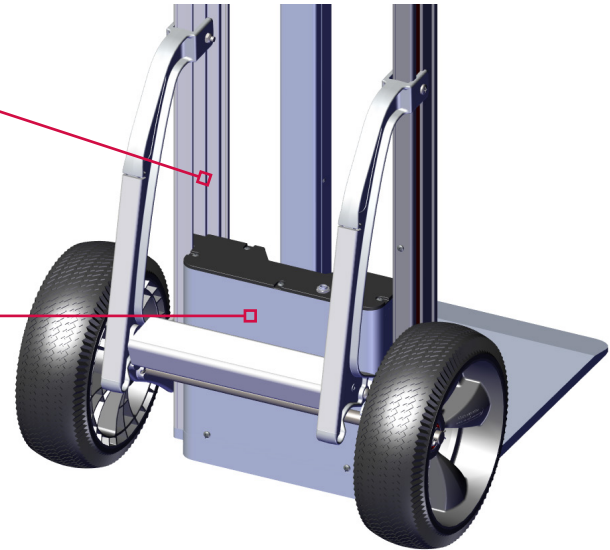

Lifting Nose Label Placement

WARNING

Falling Hazard. Do not stand on lift platform.
Do not exceed rated weight capacity - 200 lbs.
Tipping Hazard. Keep load centered.
Make sure lifting platform is securely attached to lifting mechanism.



Lifting nose for cylindrical loads (#521725)

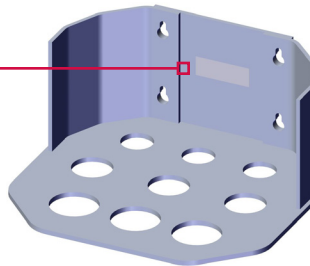

WARNING

Falling Hazard. Do not stand on lift platform.
Do not exceed rated weight capacity - 125 lbs.
Tipping Hazard. Keep load centered.
Make sure lifting platform is securely attached to lifting mechanism.



Lifting Nose for Flat Loads (#521730)

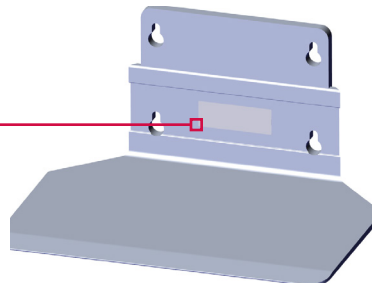

Accessories	Part Number
Lifting nose for cylindrical loads	521725
Lifting nose for flat loads	521730
Keg stabilizer - pair	521910
Replacement Parts	Part Number
AC charger	63081
Rear panel assembly	521178
Axle - 18" long	22101
Wheel bracket - RH	210100
Wheel bracket - LH	210101
Cotter pin	81077
Washer - thick	80705
Washer - thin	80707
Axle roll pin - 1/8" x 1/1/8" long	190104
Fixed nose plate - 16" wide x 14" deep	521182
Flat head screw - 5/16"-18 x 1-1/4" long	802030
Flat head screw - 5/16"-18 x 1-3/4" long	802036
Hex lock nut - 1/4"-20	80675
Hex lock nut - 5/16"-18	80676
Motor assembly	521510
Battery - 19.2V 5Ah lithium LiFePO ₄	521670

Lifting nose mounting bolts	802040
Handle mounting bolt	80105
Wheel - 10" x 3.5" 4-ply tube-type pneumatic with semi-precision bearings	121060
Wheel - 10" x 3.5" microcellular foam with semi-precision bearings	131010
Wheel - 10" x 3.5" interlocking microcellular foam with semi-precision bearings	111080
Wheel - 10" x 2" interlocking microcellular foam with semi-precision bearings	111070
Wheel - 10" x 2.75" interlocking microcellular foam with semi-precision bearings	111075
Handle - No. 11 standard U	301000
Handle - No. 17 straight loop with pistol grip	301004
Handle - No. 18 with 18 degree bend (3" higher than No. 11)	301005
Handle - No. 19 standard U-loop with vinyl sleeve with	301008
Handle - No. 24 square loop handle	301001

Handle - No. 28 square loop handle with foam sleeve	301188
Handle - No. 30 welded double grip	301137
Up/Down switch	521698
On/Off switch	521693
Limit switch cover	521157
Upper limit switch	521687
Motor drive controller	521652
Fuse - 5A, 32 VDC	61211
Fuse - 30A, 32 VDC	61210

Regulations

Model: LTXXXXXXXXXX
 Magline®, Inc.
 1205 W Cedar St.
 Standish, MI 48658 USA
 800-624-5463
www.magliner.com/regulations



This device complies with part 15 of the FCC Rules. Operation is subject to the following two conditions: (1) This device may not cause harmful interference, and (2) this device must accept any interference received, including interference that may cause undesired operation.

CAN ICES-003(A) / NMB-003(A)

Note: This equipment has been tested and found to comply with the limits for a Class A digital device, pursuant to part 15 of the FCC Rules. These limits are designed to provide reasonable protection against harmful interference when the equipment is operated in a commercial environment. This equipment generates, uses, and can radiate radio frequency energy and, if not installed and used in accordance with the instruction manual, may cause harmful interference to radio communications. Operation of this equipment in a residential area is likely to cause harmful interference in which case the user will be required to correct the interference at his own expense.

NOTICE:

Changes or modifications not expressly approved by Magline, Inc may void the user's authority to operate this device under FCC regulations and must not be made.



MAGLINE® INC.
1205 West Cedar Street
Standish, Michigan 48658
1-800-MAGLINE (624-5463)
Email: customerservice@magliner.com
www.magliner.com

Form # B9514
© Copyright 2021, Magline, Inc.
Patent: www.magliner.com/patents